

Selfishness, Not Always A Nightmare: Modeling Selfish MAC Behaviors in Wireless Mobile Ad Hoc Networks

Lin Chen, Jean Leneutre

École Nationale Supérieure des Télécommunications

Lin.Chen@enst.fr, Jean.Leneutre@enst.fr

Abstract—In wireless mobile ad hoc networks where nodes are selfish and non-cooperative, a natural and crucial question is how well or how bad the MAC layer protocol IEEE 802.11 DCF performs. In this paper, we study this question by modeling the selfish MAC protocol as a non-cooperative repeated game where players follow the TIT-FOR-TAT (TFT) strategy which is regarded as the best strategy in such environments. We show for single-hop ad hoc networks the game admits a number of Nash Equilibria (NE). We then perform NE refinement to eliminate the inefficient NE and show that there exists one efficient NE maximizing both local and global payoff. We also propose an algorithm to approach the efficient NE. We then extend our efforts to multi-hop case by showing that the game converges to a NE which may not be globally optimal but quasi-optimal in the sense that the global payoff is only slightly less than the optimal case.

As conclusion, we answer the posed question by showing that selfishness does not always lead to network collapse. On the contrary, it can help the network operate at a NE globally which is optimal or quasi-optimal under the condition that players are long-sighted and follow the TFT strategy.

Keywords: Wireless ad hoc network, IEEE 802.11 DCF, Game theory, Markov chain.

I. INTRODUCTION

The IEEE 802.11 DCF (Distributed Coordination Function) has become the most popular MAC layer protocol of ad hoc networks. It requires all network participants to respect its rules. However, network adapters are becoming more and more programmable, which makes a selfish node extremely easy to tamper the wireless interface (e.g., modifying the Contention Window (CW) value) to maximize its own benefit. Under this circumstance, a natural and crucial question we pose is that how well or how bad IEEE 802.11 DCF performs if all nodes are selfish. More specifically, in such distributed environment as ad hoc networks where coordination or punishment mechanisms are expensive or even impossible to implement, can IEEE 802.11 DCF survive or does it lead to network collapse?

We answer the question by establishing a game theoretical model of IEEE 802.11 DCF in selfish environment and studying the network performance at the Nash Equilibria (NE). We show both analytically and numerically that selfishness does not always lead to network collapse. On the contrary, it can help the network operate at an efficient NE globally optimal or quasi-optimal under the condition that players are long-sighted and follow the TIT-FOR-TAT (TFT) strategy which is regarded as the best strategy in non-cooperative environments. We believe these are reasonable conditions for participants of ad hoc networks.

The rest of the paper is organized as follows. In Section II, we briefly review the related work. In Section III, we extend Bianchi's model to selfish environments where

nodes may operate on different CW values. Based on this model, we formulate the non-cooperative multi-stage MAC game in Section IV. In Section V, we solve the game by showing the existence of NE and performing NE refinement to eliminate the inefficient NE. We then extend our work to multi-hop ad hoc networks in Section VI. Section VII provides numerical results. Section VIII discusses some related issues. Section IX concludes the paper.

II. RELATED WORK

Game theory is a powerful tool in modeling interactions among self-interested users and predicting their choice of strategies. It is widely employed to study the non-cooperative behaviors on the network layer. Much less work has been done on the MAC layer, among which [6] studies the noncooperative equilibria of Aloha networks for heterogeneous users. [4] studies the stability of multi-packet slotted Aloha with selfish users and perfect information, [5] reconsider the same Aloha game with partial information, where the transmission probability is adapted according to collision feedback.

In the context of MAC protocols of IEEE 802.11, [7] shows that the 802.11 MAC protocol leads to inefficient equilibria if users configure their packet size and data rate to maximize their own throughput. [2] shows that the existence of small population of selfish nodes leads to network collapse. The authors thus propose a penalizing scheme to prevent the network from being paralyzed.

Existing work shows that without coordination among nodes, selfish behaviors degrade the network performance or even paralyze the system. Thus punish or incentive mechanisms are needed to encourage nodes to adopt socially optimal behaviors. However, in our work, by introducing TFT, a natural strategy in non-cooperative environments, we show that even without any coordination or incentive mechanisms which may be expensive or even impossible to implement in ad hoc environments, selfishness does not lead to network collapse. On the contrary, selfishness can help the network operate at an equilibrium which is globally optimal or quasi-optimal under the condition that players are long-sighted and follow the TFT strategy.

III. MODELING IEEE 802.11 DCF WITH SELFISH NODES

We consider a wireless ad hoc network consisting of a set $\mathcal{N} = \{1, 2, \dots, n\}$ of selfish nodes within the same communication range (i.e., each node can hear any other node). By selfish we mean that each node can configure its own CW value. We assume that the network is sa

i.e., each node always has packets to send and the packets are of the same size.

We develop a Markov chain model based on Bianchi's model [1] taking into consideration the selfish feature of nodes. The initial CW value of node i is denoted by W_i .

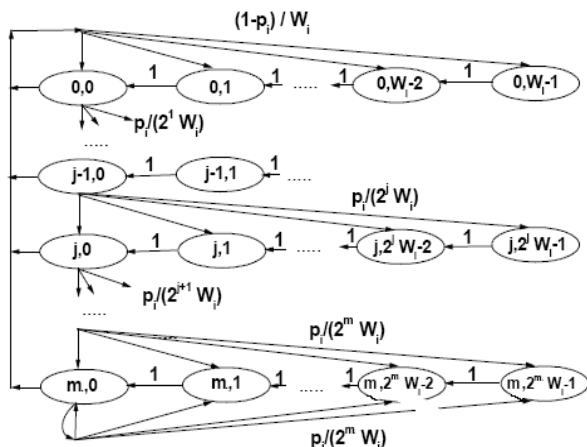

Fig. 1. The Markov Chain model

In the j^{th} stage, it becomes $2^j W_i$ ($0 < j < m$, m is the maximum backoff stage). τ_i denotes the transmission probability of i in a random slot. p_i denotes the collision probability of i when it transmits a packet in a random slot. As illustrated in Figure 1, each state is denoted by the couple (s, b) representing the backoff stage and CW value. The two-dimensional discrete-time Markov chain of node i can be described by following equations:

$$\begin{cases} P\{j, k|j, k+1\} = 1 & k \in (0, 2^j W_i - 2) & j \in (0, m) \\ P\{0, k|j, 0\} = \frac{1-p_i}{W_i} & k \in (0, W_i - 1) & j \in (0, m) \\ P\{j, k|j-1, 0\} = \frac{p_i}{2^j W_i} & k \in (0, 2^j W_i - 1) & j \in (1, m) \\ P\{m, k|m, 0\} = \frac{p_i}{2^m W_m} & k \in (0, 2^m W_m - 1) \end{cases} \quad (1)$$

Based on the above descriptions of state transitions for traffic flows, we can solve the Markov chain for node i . Let $q_i(j, k)$ ($0 \leq j \leq m, 0 \leq k \leq 2^j W_i - 1$) be the stationary distribution of the chain. We express $q_i(j, k)$ by $q_i(0, 0)$.

Apply $\sum_{j=0}^m \sum_{k=0}^{2^j W_i - 1} = 1$, we get

$$\begin{aligned} q_i(0, 0) &= \frac{2(1-2p_i)(1-p_i)}{(1-2p_i)(W_i+1) + p_i W_i (1-(2p_i)^m)} \\ \tau_i &= \sum_{j=0}^m q_i(j, 0) = \frac{2(1-2p_i)}{(1-2p_i)(W_i+1) + p_i W_i (1-(2p_i)^m)} \\ &= \frac{2}{1+W_i + p_i W_i \sum_{j=0}^{m-1} (2p_i)^j} \end{aligned} \quad (2)$$

Furthermore we have the following equation on the relation between τ_i and p_i : p_i is the probability that at least one of the other $(n-1)$ nodes transmit in the slot:

$$p_i = 1 - \prod_{j \in \mathcal{N}, j \neq i} (1 - \tau_j) \quad (3)$$

Combining the equation (2) and (3) of all nodes i , we get $2n$ equations with $2n$ variables $\tau_1, \dots, \tau_n, p_1, \dots, p_n$, which can be solved numerically. [1] has shown that if all nodes choose the same CW values, the Markov chain model admits a unique solution.

As an application, the above model can be used to calculate the normalized throughput S , defined as the fraction of time of successful transmission on the channel:

$$S = \frac{S_{slot}}{T_{slot}} = \frac{P_s P_{tr} E[P]}{(1-P_{tr})\sigma + P_{tr} P_s T_s + P_{tr}(1-P_s)T_c}$$

where S_{slot} is the time to successfully transmit a packet, T_{slot} is the average slot length, $E[P]$ is the average packet payload size, $P_{tr} = 1 - \prod_{j \in \mathcal{N}} (1 - \tau_j)$ is the probability that there is at least one transmission in the considered slot time, $P_s = \frac{\sum_{i \in \mathcal{N}} \tau_i \prod_{j \in \mathcal{N}, j \neq i} (1 - \tau_j)}{P_{tr}}$ is the probability that exactly one node transmits on the channel conditioned by at least one node transmits. The average length of a slot time is obtained considering that, with probability $1 - P_{tr}$, the slot time is empty, with probability $P_{tr} P_s$, it contains a successful transmission, and with probability $P_{tr}(1 - P_s)$, it contains a collision. T_s is the average time the channel is sensed busy due to a successful transmission, T_c is the average time the channel is sensed busy by each node during a collision. σ is the empty slot duration. In basic IEEE 802.11 DCF without RTS/CTS dialogue, assuming the packet sized is the same for all packets, let H be the time to transmit the packet header including PHY and MAC header and P is the time to transmit a packet, neglecting the propagation delay, we have:

$$\begin{cases} T_s = H + P + SIFS + ACK + DIFS \\ T_c = H + P + SIFS \end{cases}$$

IV. GAME THEORETICAL MODEL AND PROBLEM FORMULATION

In this section, we study the selfish MAC behaviors using game theory. All nodes are selfish, rational and do not cooperative in managing their communication. They are also energy-constrained. Each node i chooses its CW value W_i to maximize its own benefit described by a utility function defined as

$$u_i = \frac{\tau_i [(1-p_i)g_i - e_i]}{T_{slot}}$$

where g_i is the gain of node i when successfully transmitting a packet, e_i is the cost of sending a packet, T_{slot} is the average slot length. u_i , expressed as the expected gain during a slot time divided by the slot length, can be regarded as the expected gain per unit time. To simplify the problem, we assume that g_i and e_i are the same for all i , denoted respectively as g and e . Now we are ready to introduce our non-cooperative MAC game.

We model the IEEE 802.11 MAC protocol as finite repeated game with unpredictable end time, which means that the players cannot predict the end time of the game. This is often the case in strategic interactions, in particular networking operations. In game theory this

modeled as infinite multi-stage game with discount. The discount factor is usually very close to 1, indicating that the players is in general long-sighted. The game starts at time 0 and each stage lasts T . The players of the game are all the nodes in the network. The strategy set of the players is the CW value set $\mathcal{W} = \{1, 2, \dots, W_{max}\}$. The strategy profile W^k played in the k^{th} stage is thus the n-tuple of individual's stage game strategies.

$$W^k = (W_1^k, \dots, W_n^k), W_i^k \in \mathcal{W}$$

We denote the correspondent transmission probability profile and collision probability profile in stage k as: $\tau^k = (\tau_1^k, \dots, \tau_n^k)$ and $p^k = (p_1^k, \dots, p_n^k)$

In the game, each player i chooses its CW value for the k^{th} stage $W_i^k \in \mathcal{W}$ at the beginning of the stage and operates on W_i^k for whole stage. The decision of W_i^k is made based on previous actions of other players. We now give the formal definition of the game.

Definition 1: The non-cooperative IEEE 802.11 MAC game \mathcal{G} is a 4-tuple $(\mathcal{P}, \mathcal{S}, \mathcal{U}, \delta)$, where $\mathcal{P} = \mathcal{N}$ is the player set, $\mathcal{S} = \times_{i \in \mathcal{P}} \mathcal{W}$ is the strategy space, $\mathcal{U} = \{U_1, \dots, U_n\}$ is the utility function space where $U_i = \sum_{k=0}^{+\infty} \delta^k U_i^s(W^k)$ is the

utility function expressed as the sum of the utility in each stage k , $U_i^s(W^k) = u_i(W^k)T$ is the stage utility function, δ is the discounting factor which is generally close to 1.

In \mathcal{G} , players are self-interested and rational, thus they adopt the strategy that maximizes their own payoff. A natural choice is the TFT strategy, a well known strategy in game theory which is shown to be the best strategy in non-cooperative environments and is the root of an ever growing amount of other successful strategies. The core idea of TFT is to cooperate for the first stage and then follow the opponent's last move for the coming stage. Before tailoring the TFT strategy for our context and describing how i adjusts its W_i^k according to TFT strategy, we need to get a more in-depth insight on the stage payoff.

Lemma 1: For any two players i, j , if $W_i^k > W_j^k$, then it holds that $p_i^k > p_j^k$, $\tau_i^k < \tau_j^k$ and $U_i^s(W^k) < U_j^s(W^k)$.

Proof: See Appendix A for the sketch of the proof. ■

Now we are ready to introduce the following TFT strategy in our context:

- In each stage k , each player i measures the CW value of any other player j in the last stage (How to observe CW values in saturated networks is addressed in [3]).
- Set $W_i^k = \min_{j \in \mathcal{P}} \{W_j^{k-1}\}$

The argument behind this is that in selfish environment each rational player is expected to take action to increase its payoff if any other player gets more and will follow the previous action if no player get more payoff than itself. TFT strategy has following desirable properties: (1) The decision is made solely on local measurement. (2) It is simple to implement and only the measurement of the last stage needs to be stored. (3) It is especially suitable for wireless ad hoc networks in that the broadcast nature makes the observation very easy in promiscuous mode. (4) It ensures the fairness among players. By applying it all

players converge to the same CW value, otherwise the players with greater CW values will decrease them according to their measurement so as not to be disfavored. Thus within finite number of stages all players will operate on the same CW value which yields the same utility and throughput.

In practice, taking into account the various factors that influence the measurement, a more tolerant version of TFT called Generous TFT (GTFT) can be applied:

- Each player i measures the CW value of any other player in the last r_0 stages (from stage $k - r_0$ to stage $k - 1$)
 - If there exists player l such that $\overline{W}_l < \beta \overline{W}_i$ ($\overline{W}_j = \frac{1}{r_0} \sum_{r=k-r_0}^{k-1} W_j^r, \forall j \in \mathcal{P}$), then set $W_i^k = \min_{j \in \mathcal{P}} \{\overline{W}_j\}$
 - Otherwise set $W_i^k = W_i^{k-1}$
- $\beta < 1$ is the tolerance parameter which is close to 1. By increasing r_0 or decreasing β , the strategy becomes more tolerant.

V. SOLVING THE GAME

A. Nash Equilibrium of the Game

Game theoretic models are often analyzed using the concept of Nash Equilibrium (NE), which can be seen as optimal "agreements" between the opponents of the game. The Nash Equilibrium concept offers a predictable, stable outcome of a game where multiple agents with conflicting interests compete through self-optimization and reach a point where no player wishes to deviate. However, such a point does not necessarily exist. First, we investigate the existence of NE in \mathcal{G} .

As discussed in last section, all players converge to the same CW value. Assume that from the stage t_0 , the CW values of all nodes converge to W_c . The transmission probability of all nodes converges to τ_c . Thus $\tau_i^k = \tau_i = \tau_c$ for all $i \in \mathcal{P}$ when $k \geq t_0$. The utility function of i can be expressed as a function of τ_i (expressing U_i as a function of τ_i is equivalent to expressing U_i as a function of W_i while expressing U_i by τ_i facilitates the following demonstration)

$$U_i = \sum_{k=0}^{+\infty} \delta^k U_i^k T = \sum_{k=0}^{t_0-1} \delta^k U_i^k T + \sum_{k=t_0}^{+\infty} \delta^k U_i^k T = \sum_{k=0}^{t_0-1} \delta^k U_i^k T + \frac{\delta^{t_0} T}{1-\delta} \frac{\tau_i((1-p_i)g - e)}{T_{slot}}$$

Given that δ is close to 1, we can ignore $\sum_{k=0}^{t_0-1} \delta^k U_i^k T$ in the utility function. After some mathematic operations calculating T_{slot} , we get:

$$U_i(\tau_i) = \frac{\delta^{t_0} T}{1-\delta} *$$

$$\frac{\tau_i \prod_{j \in \mathcal{N}}^{j \neq i} (1 - \tau_j) g - \tau_i e}{\prod_{j \in \mathcal{N}} (1 - \tau_j)^{\sigma} + \sum_{j \in \mathcal{N}} \tau_j \prod_{k \in \mathcal{N}}^{k \neq j} (1 - \tau_k) T_s + [1 - \prod_{j \in \mathcal{N}} (1 - \tau_j) - \sum_{j \in \mathcal{N}} \tau_j \prod_{k \in \mathcal{N}}^{k \neq j} (1 - \tau_k)] T_c}$$

Lemma 2: $U_i(\tau_i)$ is concave w.r.t τ_i under the condition $g \gg e$.

Lemma 3: Let Γ_c denote the profile where $\tau_i = \tau_c$ for all $i \in \mathcal{P}$, it holds that $U_i(\Gamma_c)$ admits a unique maximizer $\tau_c = \tau_c^*$ and $0 < \tau_c^* < 1$.

Proof: See Appendix B for the sketch of the proof. ■

Noticing the one-to-one relation between W_c and τ_c , we can prove that there exists a unique W_c maximizing $U_i(\Gamma_c)$. We can also prove that U_i is monotonously increasing w.r.t. τ_c before τ_c^* and monotonously decreasing after it. Furthermore, noticing that τ_c is monotonously decreasing w.r.t. W_c (This can be proven by combining (2), (3) and $\tau_i = \tau_c$, $W_i = W_c$ then showing $\frac{\partial \tau_c}{\partial W_c} < 0$), it follows that U_i is monotonously increasing w.r.t. W_c before it is maximized and monotonously decreasing after that.

Now we introduce the following theorems on the Nash Equilibrium of \mathcal{G} .

Theorem 1: The game \mathcal{G} admits at least one NE.

Proof: We have shown that the utility function of any player $U_i(\tau_i)$ is concave w.r.t. τ_i . Furthermore, it is easy to show that the strategy space of i expressed by $W_i: [1, W_{max}]$ is equivalent to the closed space $[\tau_{min}, 1]$ expressed by τ_i , where τ_{min} is the value of τ_i corresponding to W_{max} . The strategy space is thus a convex and compact set. Hence \mathcal{G} is a concave n-person game defined in [8] and thus admits at least one NE (Th1, [8]). ■

Theorem 2: Any strategy profile that all players play W_c where $W_c^0 \leq W_c \leq W_c^*$ consists of a NE of \mathcal{G} , where W_c^* is the CW value maximizing U_i , W_c^0 is the CW value satisfying $U_i(W_c^0, \dots, W_c^0) > 0$ and $U_i(W_c^0 - 1, \dots, W_c^0 - 1) < 0$.

Proof: We prove it by showing that no player has incentive to deviate from W_c . On one hand, any player i has no incentive to increase its CW value W_i because if i do so, it is disfavored and gets less payoff (see Lemma 4 for the detailed proof) and thus will set its W_i back to W_c according to the TFT strategy. On the other hand, if i decreases its W_i , say to W'_c , other players will react by decreasing their CW values to W'_c , leading to the decrease of the payoff for all players including i in following stages due to the fact that U_i is monotonously increasing w.r.t. W_c before W_c^* . For i , this decrease of payoff in following stages, as will be shown in Section V.D in a similar scenario, outweighs the gain obtained during the stages when i operates on W'_c while others on W_c . Thus i gets less payoff by decreasing W_i from W_c . Hence, i has no incentive to either decrease or increase its W_i when operating at W_c . It follows that W_c is a NE of \mathcal{G} . Note that (W_c, \dots, W_c) is not a NE if $W_c < W_c^0$ in that the payoff in this case is negative. ■

From Theorem 2, we can see that \mathcal{G} has $(W_c^* - W_c^0 + 1)$ NE. Usually not all of them are good. The next step is to remove those NE that are less robust or less efficient and to achieve a socially desirable result. This is achieved by NE refinement addressed in next section.

B. Nash Equilibrium Refinement

In this section, we perform NE refinement through introducing extra optimality criteria which are *fairness*, *social welfare maximization* and *Pareto optimality*.

Fairness: It is clear that all the NE of \mathcal{G} achieve fairness

among players due to the TFT strategy in that each player chooses the same CW value and gets the same payoff after the convergence.

Social Welfare Maximization: Here the social welfare refers to the sum of the players's payoff, which reflects the global optimality. Among the NE, (W_c^*, \dots, W_c^*) maximizes both individual payoff U_i and the global payoff $\sum_{i \in \mathcal{P}} U_i = nU_i$. In fact it is the only NE maximizing the global payoff. The network operating on the NE (W_c^*, \dots, W_c^*) achieves the global optimality.

Pareto Optimality: It is easy to check that (W_c^*, \dots, W_c^*) is the only Pareto optimal NE. All other NE are not Pareto optimal in that for any $W_c \neq W_c^*$, $U_i(W_c, \dots, W_c) < U_i(W_c^*, \dots, W_c^*)$.

The NE refinement leads to a unique efficient NE (W_c^*, \dots, W_c^*) maximizing both local and global payoff.

C. Approaching the Efficient Nash Equilibrium

In this section, we address the issue on how to reach the efficient NE obtained in Section V.B. It is worth nothing if the network cannot approach the efficient NE and operate on it. If the number of the nodes n in the network is known to players, the task becomes trivial in that the CW value of the efficient NE can be computed given n . In some cases, the network participants do not know the number of nodes in the network, so they cannot directly calculate W_c^* . Thus an algorithm is needed to search W_c^* . Next we provide such a simple algorithm. Of course there exist better algorithms achieving the same goal. Our objective here is to show the necessity and the possibility of providing such an algorithm rather than seek the best one.

The core idea is that one node l starts the search and all nodes then the search for the CW value that maximizes l 's payoff under the condition that they operate on the same CW value. According to the analysis in previous section, this value is W_c^* . The algorithm requires all players to act cooperatively. This does not contradict to the selfish nature of players in that players are selfish in the sense that their goal is to maximize their payoff, thus they have incentive to act cooperatively to reach the efficient NE which will maximize their payoff as well as the global payoff.

An algorithm to approach the efficient NE

1. Any node l sends a message Start-Search containing the CW value of the starting point $W_l = W_0$ and starts the search.
2. Right-Search: l increases W_l by 1 and sends a message Ready including the new W_l . Other nodes set their CW values to W_l when receiving the message Ready.

l waits for a short period t for others to change their CW values and measures its payoff in the following t_m time. The payoff can be calculated as follows: $\bar{U}_l = (n_s g - n_e e) / t_m$, where n_s is the number of packets successfully emitted, n_e is the number of packets emitted. If the payoff is greater than the last measured payoff with the old W_l , l continues the search until the payoff decreases. l notes the last CW value W_m before decreasing.

3. Left-Search: If $W_m \neq W_0 + 1$, skip Left-search. Otherwise l decreases W_l by 1 and sends the message Ready including the new W_l . Others set their contention window to W_l when receiving the message Ready.

l waits or a short period t for other nodes to change their CW values and measures its payoff in the following t_m time. If the payoff is greater than the last measured payoff, l continues the search until the payoff decreases. l notes the last CW value W_m before decreasing.

4. l broadcasts W_m as the CW value of the efficient NE.

Remark: In the proposed algorithm, one may ask what is the consequence if l broadcasts $W'_m \neq W_m = W_c^*$ while operates on W_c^* itself. Actually l has no incentive to broadcast $W_m < W_c^*$ since this will lead the players to operate on W_m according to TFT strategy. As a result, l gets less payoff compared with the case where it reports W_c^* and operates on W_c^* . If l broadcasts $W_m > W_c^*$, the CW values will converge to W_c^* . The only benefit of l is that it may get certain amount of payoff before the convergence. However, as shown in previous part of this section, the payoff obtained before the convergence is negligible compared with the total payoff.

D. Impact of Short-sighted Players

In previous sections a basic assumption is that all players are long-sighted ($\delta \rightarrow 1$). In this section we relax it to study the impact of short-sighted players on the network performance. We first introduce the following lemma.

Lemma 4: In \mathcal{G} where all players play the same W_k , the stage payoff of each player is $U_k^s(W^k)$, where $W^k = (W_k, \dots, W_k)$. If player i deviates from W_k to W_i , while any other player j sticks to W_k , the stage payoff of i and j is $U_i^s(W^{k'})$, $U_j^s(W^{k'})$ respectively, where $W^{k'} = (W_k, \dots, W_i, \dots, W_k)$.

(1) If $W_i > W_k$, then $U_i^s(W^{k'}) < U_k^s(W^k) < U_j^s(W^{k'})$

(2) If $W_i < W_k$, then $U_j^s(W^{k'}) < U_k^s(W^k) < U_i^s(W^{k'})$

Proof: See Appendix C for the sketch of the proof. ■

We consider the scenario where there is one short-sighted player s with the discount factor δ_s . s operates on $W_s < W_c^*$ rather than W_c^* to get more payoff.

We also assume that other nodes need m stages ($m \geq 1$) to react according to the TFT/GTFT strategy to set their contention window to W_s . Thus our game becomes the following: in the first m stages s operates on W_s while others on W_c^* ; in the following stages, all players operate on W_s . Thus the payoff of s is:

$$\begin{aligned} U_s &= \sum_{r=0}^{m-1} U_s^s(W_c^*, \dots, W_s, \dots, W_c^*) + \sum_{r=m}^{\infty} U_s^s(W_s, \dots, W_s) \\ &= \frac{1}{1 - \delta_s} [(1 - \delta_s^m) U_s^s(W_c^*, \dots, W_s, \dots, W_c^*) + \\ &\quad \delta_s^m U_s^s(W_s, \dots, W_s)] \end{aligned}$$

On the other hand, if s operate on W_c^* for all stages, its payoff is:

$$U'_s = \frac{U_s^s(W_c^*, \dots, W_c^*)}{(1 - \delta_s)}$$

We consider the following two cases:

- If s is extremely short-sighted, we have $\delta_s \rightarrow 0$, then according to lemma 4, we have $W_s < W_c^* \implies U_s^s(W_c^*, \dots, W_s, \dots, W_c^*) > U_s^s(W_c^*, \dots, W_c^*)$. Noticing $\delta_s \rightarrow 0$, it follows that $U_s > U'_s$. Hence by operating on W_s , s gets more payoff at the expense of others and the sub-optimality of the network as a whole.
- If s is long-sight, then it will choose W_s to maximize $\delta_s^m u_s(W_s, \dots, W_s)$ where W_c^* is the unique maximizer.

Generally, given δ_s , s can configure W_s to maximize its payoff by imposing $\frac{dU_s}{dW_s} = 0$. To conclude, a short-sighted player has negative impact on the network as a whole since it will degrade the performance or even lead to network collapse.

E. Impact of Malicious Players

Unlike selfish players, the malicious players aim at collapsing the network. Hence they have no incentive to operate on the efficient NE W_c^* . To this end, they will surely deviate from W_c^* to fulfill their goal.

We consider the scenario where malicious player i operates on $W_i < W_c^*$. Under this condition, other players will decrease their CW values to W_i based on TFT. As consequence, the network performance is degraded as the global payoff decreases. If W_i is sufficiently small, the network is paralyzed.

F. RTS/CTS Case

The Markov chain model for basic case is applicable in RTS/CTS case. What differs in RTS/CTS case is that collisions occur on RTS frames, thus

$$\begin{cases} T'_s = RTS + SIFS + CTS + H + P + SIFS + ACK + DIFS \\ T'_c = RTS + DIFS \end{cases}$$

Noticing $T'_c \ll T'_s$ and performing the same demonstration, we get the same result for RTS/CTS case.

VI. MULTI-HOP CASE

We now extend our previous work to a more challenging environment – multi-hop wireless mobile ad hoc networks. We consider a connected multi-hop wireless mobile ad hoc networks operating under RTS/CTS access mechanism. We assume that nodes know the number of neighbor nodes (e.g. via routing protocols or MAC layer beacons).

A. Markov Chain Model Adaptation

We need to modify the Markov chain model in Section III to extend the model to multi-hop case. First, under the assumption that the channel states sensed by the neighbors of a node is the same as that sensed by the node, we can rewrite (3) as

$$p_i \approx 1 - \prod_{j \in M_i, j \neq i} (1 - \tau_j) \quad (4)$$

where M_i denotes the area within i 's transmission range.

We then modify the utility function as follows to take into account the hidden node problem in multi-hop case:

$$u_i = \frac{\tau_i ((1 - p_i) p_{hn}^i g_i - e_i)}{T_{slot}}$$

where p_{hn}^i is the degradation factor indicating $1 - p_{hn}^i$ % of transmitted packets experience collisions at the receivers due to the hidden node problem. The stage and total utility function is derived in the same way as single-h

A key approximation in our model is that p_{hn}^i is independent of the CW values of players. We will show in next section via simulation that this approximation is accurate when n is large enough and CW values are not too small. Note that we cannot solve τ_i and p_i in multi-hop case with the above model without the knowledge of the network topology. However, as we will shown in following demonstration, we can establish the equilibrium of \mathcal{G}' using the adapted model, which is our goal.

B. Formulating and Solving the game

The MAC layer game in multi-hop environment \mathcal{G}' can be formulated in the same way as its counterpart \mathcal{G} . However, it is obvious that the solution of \mathcal{G} is no more applicable for \mathcal{G}' . Nevertheless, as long as players in \mathcal{G}' follow TFT strategy, their CW values will converge to the smallest one of all players after sufficiently long time although the converged value may not be optimal for all players. This can be shown intuitively: consider player s operates on the smallest CW value W_s . The neighbor of s will decrease their CW values to W_s if they operate on higher values according to TFT. Once their CW values are decreased, they have no incentive to increase it any more. Then the CW values of the 2-hop neighbors of s will converge to W_s . As a result, as long as the network is not partitioned, the CW values of all players will converge to W_s after sufficiently long time.

In multi-hop case, it is not possible to apply the algorithm in Section V.C to reach an equilibrium point due to the fact that the optimal CW value of l may not be optimal for other players. Thus they have no incentive to operate on this CW value or will not even participate in the search. In stead, any player i relies solely on local information to choose its CW value W_i . Under such circumstance, a natural way is to choose the initial value of W_i that maximizes its payoff assuming its neighbors also operate on W_i and to follow TFT in following stages. Taking into consideration the approximation that p_{hn}^i is independent of CW values and $g \gg e$, W_i is obtained by maximizing $\frac{\tau_i(1-p_i)g}{T_{slot}}$, which is the same utility function in the single-hop game \mathcal{G} in case $g \gg e$. Hence, W_i is set to the CW value at the efficient NE of the single-hop game \mathcal{G} in which the players are i and its neighbors (Here we implicitly assume that nodes with the same CW values have the same packet transmission and collision probability which is τ_i and p_i respectively. This assumption is accurate if n is sufficiently large and the density of the network does not vary too much.). The result is not surprising in that in multi-hop environments without coordination among nodes, the best strategy for a rational player is to operate on local optimal point based on local information. Under this circumstance, after sufficient long time, the CW value will converge to $W_m = \min_{i \in \mathcal{N}} W_i$. In the following theorem we prove that all players operating on W_m constitutes of a NE of \mathcal{G}' .

Theorem 3: In \mathcal{G}' , the CW values of all players converge to $W_m = \min_{i \in \mathcal{N}} W_i$, where W_i is i 's CW value at the efficient NE of the single-hop game \mathcal{G} in which the players

are i and its neighbors. It holds that $W^m = (W_m, \dots, W_m)$ is a NE of \mathcal{G}' .

Proof: We prove it by showing that any node j has no incentive to deviate from W_m . If W_m is node j 's efficient NE of local single-hop game, it is clear that j has no incentive to deviate from W_m . In other cases, j has no incentive to increase its CW in that it will be dragged back to W_m according to the TFT strategy when j meets players operating on W_m ; If j decrease its CW value to $W'_j < W_m$, then according to the TFT strategy, other nodes also decrease their CW values to W'_j . Note that under the condition that all players choose the same CW value, the payoff of j is monotonously increasing until it is maximized at W_j . Since $W'_j < W_m = \min_{i \in \mathcal{N}} W_i < W_j$, thus the payoff of j operating on W'_j is less than that on W_m . Hence j has no incentive to either decrease or increase its CW value from W_m . It follows that W_m is the NE of \mathcal{G}' . ■

Furthermore it can be shown that the above NE is Pareto optimal, but not globally optimal. Nevertheless, we will show in next section via simulation that the NE is quasi-optimal in the sense that the global payoff is only slightly outweighed by the optimal case and the fairness of the NE is ensured in the sense that each player gets almost the same payoff as the maximum payoff it can get.

VII. NUMERICAL RESULTS

We present the numerical results on our game theoretical model. The network parameters are listed in Table I.

A. Single-hop Case

We first study the efficient NE when the CW value of all players is converged. We conduct simulation in NS-2 and compare simulation results with our analytical results. Table II and III show the main results in which W_c^* is the efficient NE according to our theoretical model, $\overline{W_c^*}$ is the average CW values of each node that maximizes its own payoff in the simulation, $Var(W_c^*)$ is the variance of W_c^* . We can see that in both cases, the simulation results coincide with the analytical results quite well.

Packet size	8184 bits
MAC header	272 bits
PHY header	128 bits
ACK	112 bits + PHY header
RTS	160 bits + PHY header
CTS	112 bits + PHY header
Channel bit rate	1 Mbits/s
σ	50 μ s
SFIS	28 μ s
DIFS	128 μ s
g	1
e	0.01
T	10s
δ	0.9999
Simulation time	1000s

TABLE I
NETWORK PARAMETERS

We also trace the global payoff as a function of CW values base on our model in Figure 2 and 3, where the Y-axis is U/C where U denotes the global payoff a

n	W_c^*	\bar{W}_c^*	$Var(W_c^*)$
5	76	75.6	3.35
20	336	337.4	2.78
50	879	880.5	2.65

TABLE II
NASH EQUILIBRIUM POINT: BASIC CASE

n	W_c^*	\bar{W}_c^*	$Var(W_c^*)$
5	22	22.9	1.63
20	48	46.4	1.78
50	116	114.2	1.65

TABLE III
NASH EQUILIBRIUM POINT: RTS/CTS CASE

$\frac{gT}{\sigma(1-\delta)}$ is a constant. From the two figures especially the CTS/RTS case (Figure 3) we can see that operating at W_c^* also achieves the global social optimality. Furthermore, the efficient NE is quite robust in the sense that the CW values near W_c^* yield almost the same global and local payoff. Consequently, a rational players should be satisfied as long as it operates not too far from W_c^* . This robust and tolerant feature may significantly facilitate the design and implementation of TFT/GTFT strategy and the algorithm to reach W_c^* .

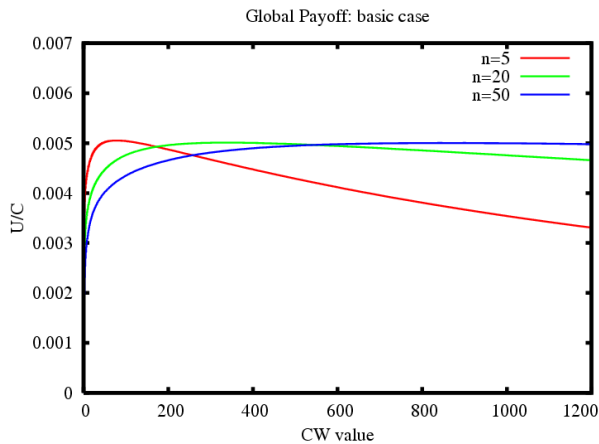

Fig. 2. Global payoff versus CW value for basic case

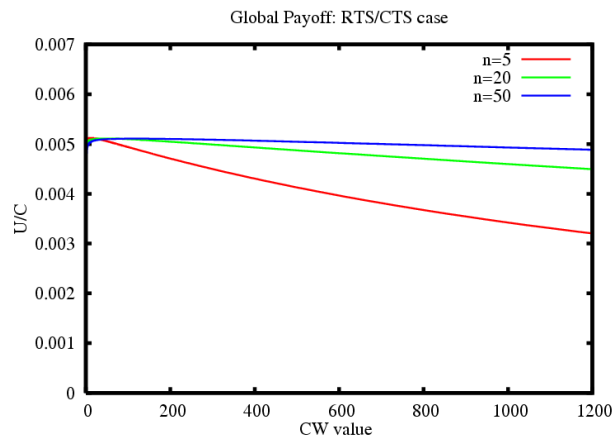

Fig. 3. Global payoff versus CW value for RTS/CTS case

B. Multi-hop Case

We simulate for 1000s a network of 100 nodes with the same transmission range of 250m moving at a speed randomly picked from $[0, 5\text{m/s}]$ according to the random waypoint model in a $1000\text{m} \times 1000\text{m}$ area. Each node has information of its neighbors from which it calculates the local optimal CW value.

We simulate the converged case by setting the converged CW value to the smallest one among the nodes. This value, 26 in our scenario, is the NE according to our analytical model. We then vary CW values to simulate both local and global payoff and compare the results with that at NE. We report that operating at NE, each node gets at least 96% of the maximal local payoff it can get by varying its CW value and the global payoff is only 3% less than the maximal global payoff. We also observe from the simulation that both the local and global payoff in RTS/CTS case is almost independent w.r.t. CW values when n is large enough in both single-hop and multi-hop cases. This independence justifies our key approximation in Section VI.A.

The above numerical results show that selfishness leads to a NE which is at least quasi-optimal if not optimal in the sense that the both local and global payoff is only slightly outweighed by the optimal case.

VIII. DISCUSSION

In Section II, we mentioned that [2] shows the existence of even small population of selfish nodes leads to network collapse. Their results seem contradictory to ours. In fact they coincide with ours. The point is that in their work, the players are selfish and short-sighted, thus they choose small CW values to maximize the short-term payoff. In our work, we provide a more general analysis in both single-hop and multi-hop networks: we first assume that the players are selfish and long-sighted and show that selfishness does not lead to network collapse; we then study the impact of the short-sighted players on the network performance in Section V.D and get the same result as [2].

In this paper, we choose a general utility function and do not take into account the delay and other factors. As a result, the CW value of NE may seem too long in some cases. To derive a more desirable NE, more factors need to be considered depending on the target application and other requirement.

IX. CONCLUSION

In this paper, we focus on the posed question: how well or how bad does IEEE 802.11 DCF perform if all nodes are selfish? We study it under a game theoretical framework. Our main results are as follows:

- In single-hop ad hoc networks, selfishness does not always lead to network collapse. On the contrary, it can help network operate at an efficient NE which is also global optimal under the condition that players are long-sighted and follow the TFT strategy.
- We provide a simple algorithm to approach the efficient NE.

- In multi-hop case, under the same condition, the network operates on a NE not globally optimal. However, we show by numerical results that the NE is quasi-optimal in the sense that the global payoff is only slightly less than the optimal case.

Furthermore, we believe that the game theoretical model proposed in this paper is a general framework that can be extended to model other selfish behaviors such as rate control by redefining the proper utility function.

APPENDICES

A. PROOF OF LEMMA 1

Proof: We provide the sketch of the proof. From (3) we have

$$1 - p_i^k = \prod_{r \in \mathcal{N}, r \neq i} (1 - \tau_r^k)$$

It follows

$$(1 - p_i^k)(1 - \tau_i^k) = \prod_{r \in \mathcal{N}} (1 - \tau_r^k) = (1 - p_j^k)(1 - \tau_j^k) \quad (5)$$

noticing (2), we get

$$(1 - p_i^k) \left(1 - \frac{2}{1 + W_i^k + p_i^k W_i^k \sum_{l=0}^{m-1} (2p_i^k)^l} \right) = (1 - p_j^k) \left(1 - \frac{2}{1 + W_j^k + p_j^k W_j^k \sum_{l=0}^{m-1} (2p_j^k)^l} \right) \quad (6)$$

Combining (5) and (6), we can prove that if $W_i^k > W_j^k$, then $p_i^k > p_j^k$ by showing it is impossible that both $W_i^k > W_j^k$ and $p_i^k < p_j^k$ hold. It then follows from (5) that $\tau_i^k < \tau_j^k$.

We then consider the stage utility $U_i^s(W^k) = u_i(W^k)T = \frac{\tau_i^k [(1 - p_i^k)g - e]}{T_{slot}} T$. We have if $W_i^k > W_j^k$, then $p_i^k > p_j^k$, $\tau_i^k < \tau_j^k \Rightarrow U_i^s(W^k) < U_j^s(W^k)$ ■

B. PROOF OF LEMMA 3

Proof: We impose $\frac{\partial U_i(\Gamma_c)}{\partial \tau_c} = 0$. Noticing $e \ll u$, after some mathematical operations, we obtain:

$$Q(\tau_c) = (1 - \tau_c)^n \sigma - [n\tau_c + (1 - \tau_c)^n] T_c - T_c = 0$$

Noticing $Q'(\tau_c) = -(n-1)(1-\tau_c)^{n-1}\sigma - T_c n + (n-1)(1-\tau_c)^{n-1}T_c < -T_c n + T_c(n-1) < 0$ It follows that $Q(\tau_c)$ is a monotonous decreasing function. On the other hand, $Q(0) = T_c > 0$, $Q(1) = -(n-1)T_c < 0$, so there exists a unique $0 < \tau_c^* < 1$ satisfying $Q(\tau_c^*) = 0$. When $\tau_c < \tau_c^*$, both $Q(\tau_c)$ and $\frac{\partial U_i(\Gamma_c)}{\partial \tau_c}$ is positive, $U_i(\Gamma_c)$ is thus monotonously increasing; When $\tau_c > \tau_c^*$, both $Q(\tau_c)$ and $\frac{\partial U_i(\Gamma_c)}{\partial \tau_c}$ is negative, $U_i(\Gamma_c)$ is thus monotonously decreasing. Therefore, τ_c^* is the unique maximizer of $U_i(\Gamma_c)$. ■

C. PROOF OF LEMMA 4

Proof: We provide the sketch of the proof by proving the first half of the lemma and the second half can be proved in the same way. In the game where all players play W_k , we have

$$1 - p_k = (1 - \tau_k)^{n-1} \quad (7)$$

$$\tau_k = \frac{2}{1 + W_k + p_k W_k \sum_{r=0}^{m-1} (2p_k)^r} \quad (8)$$

In the game where i plays W_i , any other player j plays $W_j = W_k$, we have for player i

$$1 - p_i = (1 - \tau_j)^{n-1} \quad (9)$$

$$\tau_i = \frac{2}{1 + W_i + p_i W_i \sum_{r=0}^{m-1} (2p_i)^r} \quad (10)$$

for other players j

$$1 - p_j = (1 - \tau_i)(1 - \tau_j)^{n-2} \quad (11)$$

$$\tau_j = \frac{2}{1 + W_k + p_j W_k \sum_{r=0}^{m-1} (2p_j)^r} \quad (12)$$

We now prove that $W_i > W_k \Rightarrow \tau_i < \tau_k < \tau_j$. We show $W_i > W_k \Rightarrow \tau_k > \tau_i$, otherwise if $\tau_k < \tau_i$, apply Lemma 1, we have $W_i > W_j = W_k \Rightarrow \tau_i < \tau_j$, thus we have $\tau_k < \tau_i < \tau_j$. Noticing (7) and (11), we have $p_k < p_i$. Noticing (8) and (10), it follows that $W_i > W_k$ and $p_k < p_i \Rightarrow \tau_k > \tau_i$, which contradicts with $\tau_k < \tau_i$. Thus $W_i > W_k \Rightarrow \tau_i < \tau_k$. Similarly we can prove the right side of the inequation.

We then prove that $W_i > W_j \Rightarrow U_i^s(W^{k'}) < U_k^s(W^k) < U_j^s(W^{k'})$. Noticing $T_c \simeq T_s$, $g \gg e$ and after some mathematical manipulations, we get

$$U_i^s(W^{k'}) = \frac{\tau_i g}{\frac{T_c}{(1-\tau_j)^{n-1}} - (T_c - \sigma)(1 - \tau_i)}$$

$$U_k^s(W^k) = \frac{\tau_k g}{\frac{T_c}{(1-\tau_k)^{n-1}} - (T_c - \sigma)(1 - \tau_k)}$$

We have proven $\tau_i < \tau_k < \tau_j$, so $(1 - \tau_j) < (1 - \tau_k) < (1 - \tau_i)$. Applying these results it is obvious that $U_i^s(W^{k'}) < U_k^s(W^k)$. Similarly we can prove $U_k^s(W^k) < U_j^s(W^{k'})$ ■

REFERENCES

- [1] Giuseppe Bianchi, "Performance Analysis of the IEEE 802.11 Distributed Coordination Function". IEEE JSAC., vol. 18, no.3, March 2000.
- [2] M. Cagalj, S. Ganeriwal, I. Aad and J.-P. Hubaux, "On Selfish Behavior in CSMA/CA Networks". In Proc. IEEE INFOCOM, 2005.
- [3] P. Kyasanur and N. Vaidya, "Detection and Handling of MAC Layer- Misbehavior in Wireless Networks". In Proc. DSN, June 2003.
- [4] A.B. MacKenzie and S. B. Wicher, "Stability of Multipacket Slotted Aloha with Selfish Users and Perfect Information". In Proc IEEE INFOCOM, 2003.
- [5] E. Altman, R. El Azouzi, and T. Jiménez, "Slotted Aloha as a stochastic game with partial information". In Proc WiOpt, 2002.
- [6] Y. Jin, G. Kesidis, "Equilibria of a noncooperative game for heterogeneous users of an ALOHA network". IEEE Comm. Letters, vol. 6, 2002.
- [7] G. Tan, J. Guttag, "The 802.11 MAC protocol leads to inefficient equilibria". In Proc IEEE INFOCOM, 2005
- [8] J.B. Rosen, "Existence and uniqueness of equilibrium points for concave n-person games". Econometrica, vol. 33, pp. 520-524 July 1965.